

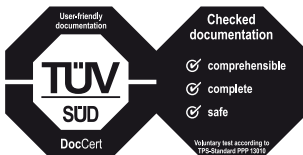

IMPRESSA J9.2 One Touch Instructions for Use



The Instructions for Use has been awarded the seal of approval by the independent German Technical Inspection Agency, TÜV SÜD, due to its easy-to-understand style, its thoroughness and coverage of safety aspects.



Your IMPRESSA J9.2 One Touch

Control elements	4
Important information	6
Proper use	6
For your safety	6
1 Preparing and using for the first time	9
JURA on the Internet	9
Setting up the machine	9
Filling the water tank	9
Filling the bean container	9
First-time use	10
Inserting and activating the filter	11
Determining and adjusting the water hardness	12
Adjusting the grinder	13
2 Preparation	14
Ristretto, espresso and coffee	14
Preparing two speciality coffees at the touch of a button	14
Latte macchiato, cappuccino	15
Warm milk and milk foam	16
Ground coffee	16
Permanently setting the amount of water for the cup size	17
Hot water	18
3 Daily operation	20
Switching on	20
Daily maintenance	20
Switching off	21
4 Permanent settings in programming mode	22
Products	23
Energy-saving mode	25
Automatic switch-off	26
Rinses	26
Restore factory settings	27
Viewing information and maintenance status	28
Unit for amount of water	29
Brightness of symbols	29
Language	30

5	Maintenance	31
	Rinsing the machine.....	31
	Rinsing the cappuccino frother	32
	Cleaning the cappuccino frother.....	32
	Dismantling and rinsing the cappuccino frother	33
	Changing the filter	33
	Cleaning the machine	35
	Descaling the machine	36
	Cleaning the bean container.....	38
	Descaling the water tank.....	39
6	Display messages	40
7	Troubleshooting	42
8	Transport and environmentally friendly disposal	44
	Transport / Emptying the system.....	44
	Disposal.....	44
9	Technical data	45
10	Index	46
11	JURA contact details / Legal information	48

Symbol description

Warnings

 CAUTION	Always take note of any information marked with the words CAUTION or
 WARNING	WARNING and a warning sign. The signal word WARNING draws your attention to potential serious injury, and the signal word CAUTION to potential minor injury.
CAUTION	CAUTION draws your attention to potential damage to the machine.

Symbols used

- | | |
|-------------------------------------------------------------------------------------|-----------------------------------------------------------------------------------------------------------------------------------------------------------|
| ▶ | Prompt to take action. This symbol means that you are being prompted to perform some action. |
|  | Information and tips to make it even easier to use your IMPRESSA. |
| @ | References to the JURA website , which provides further information that may be of interest to you: www.jura.com |

	Display
-------------------------------------------------------------------------------------	----------------

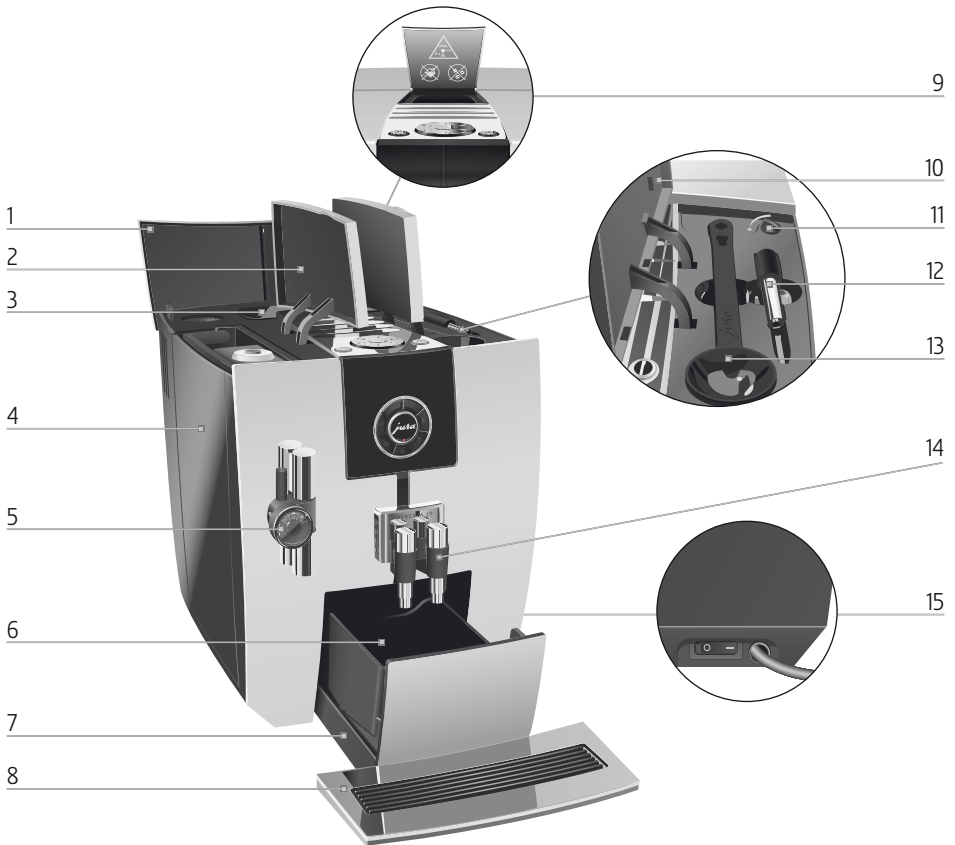

Control elements











- | | | | |
|---|----------------------------------------------|----|------------------------------------------------|
| 1 | Bean container cover | 9 | Filler funnel for ground coffee |
| 2 | Water tank cover | 10 | Storage compartment cover |
| 3 | Bean container with aroma preservation cover | 11 | Grinder adjustment switch |
| 4 | Water tank | 12 | Hot-water nozzle |
| 5 | Height-adjustable cappuccino frother | 13 | Measuring spoon for ground coffee |
| 6 | Coffee grounds container | 14 | Height- and width-adjustable coffee spout |
| 7 | Drip tray | 15 | Power switch and mains cable (side of machine) |
| 8 | Cup platform | | |



Surface of the machine

- 1  On/Off button
- 2  Rotary Switch
- 3  Maintenance button

Front

- 4  Display
- 5  Preparation buttons
 -  Ristretto button
 -  Espresso button
 -  Coffee button
 -  Hot Water button
 -  Milk button
 -  Latte Macchiato button
 -  Cappuccino button

Important information

Proper use

The machine is designed and intended for private domestic use. It should only be used for coffee preparation and to heat milk and water. Use for any other purpose will be deemed improper. JURA Elektroapparate AG cannot accept any responsibility for the consequences of improper use.

Before using the machine read these instructions for use thoroughly and completely and comply with the instructions they contain. A warranty service is not applicable for damage or defects caused by non-compliance with the instructions for use. Keep these instructions for use close to the machine and pass them on to the next user.

For your safety

Please carefully read and observe the important safety information set out below.



To avoid danger of potentially fatal electric shock:

- Never use a machine which is damaged or has a defective mains cable.
- In the event of signs of damage, for example if there is a smell of burning, unplug the machine immediately from the mains supply and contact JURA service.
- If the mains cable of this machine is damaged, it must be repaired either directly by JURA or by an authorised JURA service centre.
- Make sure that the IMPRESSA and the mains cable are not located close to hot surfaces.
- Be careful to ensure that the mains cable is not trapped and does not rub against sharp edges.
- Never open and repair the machine yourself. Do not modify the machine in any way that is not described in these instructions for use. The machine contains live parts. If opened, there is a danger of potentially fatal injury. Repairs may only be carried out by authorised JURA service centres, using original spare parts and accessories.

- To completely and safely disconnect the machine from the power supply, first switch off the IMPRESSA using the On/Off button and then at the power switch. Only then should you remove the mains plug from the power socket.

There is a risk of scalds or burns on the spouts and the cappuccino frother.

- Place the machine out of the reach of children.
- Do not touch any hot parts. Use the handles provided.
- Ensure that the cappuccino frother is correctly fitted and clean. If incorrectly fitted or if they become blocked, the cappuccino frother or its parts might come off.

A defective machine is not safe and could cause injury or fire. To avoid damage and any associated risk of injury or fire:

- Never allow the mains cable to loosely hang down. The mains cable could pose a tripping hazard or become damaged.
- Protect the IMPRESSA from environmental influences such as rain, frost and direct sunlight.
- Do not immerse the IMPRESSA, mains cable or connections in water.
- Do not put the IMPRESSA or any individual parts in the dishwasher.
- Switch your IMPRESSA off at the power switch before any cleaning operation. Always wipe the IMPRESSA with a damp cloth rather than a wet one, and protect it from prolonged exposure to water splash.
- Only connect the machine to the mains voltage in accordance with the information on the rating plate. The rating plate is located on the underside of your IMPRESSA. Further technical data is provided in these instructions for use (see Chapter 9 'Technical data').
- Please only use original JURA maintenance products. Use of products that are not explicitly recommended by JURA could damage the IMPRESSA.
- Do not use any coffee beans treated with additives or caramelised coffee beans.

Important information

- Only fill the water tank with fresh, cold water.
- Switch the machine off at the power switch if you are going to be absent for a longer period of time.

People, including children, who

- do not have the physical, sensory or mental capabilities to use the machine safely or
- are inexperienced or lack knowledge in how to use the machine safely

must be supervised by a responsible person when using it, or must be instructed in how to use it correctly.

Safety when handling the CLARIS Blue filter cartridge:

- Filter cartridges should be kept out of the reach of children.
- Store filter cartridges in a dry place in the sealed packaging.
- Protect cartridges from heat and direct sunlight.
- Do not use damaged filter cartridges.
- Do not open filter cartridges.

1 Preparing and using for the first time

JURA on the Internet

Visit us on the Internet.

- ④ You can download **short operating instructions** for your machine from the JURA website (www.jura.com). You will also find interesting and up-to-date information on your IMPRESSA and on every aspect of coffee.

Setting up the machine

When setting up your IMPRESSA, please note the following:

- Place the IMPRESSA on a horizontal surface that is not sensitive to water.
- Choose a spot for your IMPRESSA which protects the machine against overheating. Ensure that the ventilation slots are not covered.

Filling the water tank

To enjoy the perfect cup of coffee we recommend changing the water every day.

CAUTION

Milk, sparkling mineral water or other liquids can damage the water tank or the machine.

- ▶ Only fill the water tank with fresh, cold water.
-
- ▶ Open the water tank cover.
 - ▶ Remove the water tank and rinse it with cold water.
 - ▶ Fill the water tank with fresh, cold water and reinsert the tank.
 - ▶ Close the water tank cover.

Filling the bean container

The bean container has an aroma preservation cover. This will ensure that your coffee beans retain their aroma for longer.

CAUTION

Coffee beans which have been treated with additives (e.g. sugar), preground coffee or freeze-dried coffee will damage the grinder.

- ▶ Only use untreated coffee beans to refill the bean container.
-
- ▶ Open the bean container cover and remove the aroma preservation cover.
 - ▶ Remove any dirt or foreign objects from inside the bean container.

- ▶ Fill the bean container with coffee beans, then close the aroma preservation cover and the bean container cover.

First-time use









WARNING

If the machine is operated with a defective mains cable, there is a danger of potentially fatal electric shock.

- ▶ Never use a machine which is damaged or has a defective mains cable.



Precondition: The water tank and bean container are full.

- ▶ Insert the mains plug into a power socket.
-  ▶ Switch on the IMPRESSA using the power switch on the right-hand side of the machine.
-  ▶ Press the On/Off button to switch the IMPRESSA on. The Rotary Switch lights up. **SPRACHE DEUTSCH** appears on the display.
-  ▶ Turn the Rotary Switch until the required language is displayed, for example **LANGUAGE ENGLISH**.
-  ▶ Press the Rotary Switch to confirm the language. **CONFIRMED** appears briefly on the display to confirm the setting. **FILL SYSTEM / PRESS RINSE**, the Maintenance button  lights up.
- ▶ Place a receptacle under the cappuccino frother.
-  ▶ Press the Maintenance button. **SYSTEM FILLS**, the system fills up with water. The operation stops automatically and **WELCOME TO JURA** appears on the display. **HEATING UP** **PRESS RINSE**, the Maintenance button  lights up.
- ▶ Place a receptacle under the coffee spout.
-  ▶ Press the Maintenance button. **MACHINE RINSING**, the machine rinses. The operation stops automatically. **COFFEE READY** appears on the display. Your IMPRESSA is ready for use.
-  **i** The buttons for the products you can prepare are illuminated.









Inserting and activating the filter

Your IMPRESSA no longer has to be descaled if you are using the CLARIS Blue filter cartridge.

- i** Perform the 'inserting the filter' operation without any interruptions. This will ensure that your IMPRESSA always produces its best.

Precondition: **COFFEE READY** is displayed.

-  ▶ Press **and hold** the Rotary Switch until **MAINTENANCE** appears on the display.
-  ▶ Turn the Rotary Switch until **FILTER NO** is displayed.
-  ▶ Press the Rotary Switch to enter the programme item.
FILTER NO
-  ▶ Turn the Rotary Switch until **FILTER YES** is displayed.
-  ▶ Press the Rotary Switch to confirm the setting.
CONFIRMED appears briefly on the display.
INSERT FILTER / PRESS RINSE, the Maintenance button  lights up.
- ▶ Remove the filter cartridge extension from the Welcome Pack.
- ▶ Fit the filter extension on top of a CLARIS Blue filter cartridge.
- ▶ Remove and empty the water tank.
- ▶ Open the filter holder and insert the filter cartridge into the water tank, exerting slight pressure.
- ▶ Close the filter holder. It will click into place audibly.

- i** After two months, the filter will cease to work. You can check the elapsed time by referring to the date plate on the filter holder in the water tank.

- ▶ Fill the water tank with fresh, cold water and reinsert the tank.
- ▶ Place a receptacle (at least 500 ml) under the cappuccino frother.
-  ▶ Press the Maintenance button.
FILTER RINSING, water flows out of the cappuccino frother.

- i** You can interrupt rinsing of the filter at any time by pressing any button. Press the Maintenance button , to continue with rinsing of the filter.



1 Preparing and using for the first time

- i** The water may be slightly discoloured. This is not harmful to health and does not affect the taste.

Rinsing of the filter stops automatically after approximately 500 ml. The machine heats up. **COFFEE READY** appears on the display. The filter is activated.

Determining and adjusting the water hardness

- i** If you are using the CLARIS Blue filter cartridge and have activated it in programming mode, you will not be able to adjust the water hardness.

The harder the water is, the more frequently the IMPRESSA needs to be descaled. It is therefore important to adjust the water hardness.

The water hardness can be adjusted on a continuous scale between 1° dH and 30° dH. It can also be deactivated, which means that the IMPRESSA will not let you know when it has to be descaled.

Determining the water hardness

You can find out what the water hardness is by using the Aquadur® test strip supplied as standard.

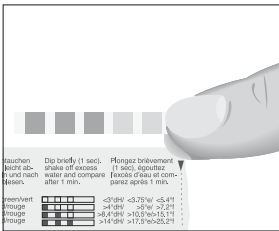

- ▶ Hold the test strip briefly (for 1 second) under flowing water. Shake off the water.
 - ▶ Wait for about one minute.
 - ▶ You will then be able to read the degree of water hardness from the discolouration of the Aquadur® test strip and the description on the packaging.
- You can now adjust the water hardness.



Adjusting the water hardness

Example: Proceed as follows to change the water hardness from 16° dH to 25° dH.

Precondition: **COFFEE READY** is displayed.

-  ▶ Press **and hold** the Rotary Switch until **MAINTENANCE** appears on the display.
-  ▶ Turn the Rotary Switch until **HARDNESS 16° dH** is displayed.

- ▶ Press the Rotary Switch to enter the programme item.
16° JH ■■■■ □□
- ▶ Turn the Rotary Switch until 25° JH ■■■■ ■■■■ is displayed.
- ▶ Press the Rotary Switch to confirm the setting.
CONFIRMED appears briefly on the display.
HARDNESS 25° JH
- ▶ Turn the Rotary Switch until EXIT is displayed.
- ▶ Press the Rotary Switch to exit programming mode.
COFFEE READY appears on the display.

Adjusting the grinder

You can adjust the grinder on a continuous scale to suit the degree of roast of your coffee.

CAUTION

If you adjust the consistency of grind when the grinder is not operating, the grinder adjustment switch could be damaged.

- ▶ Only adjust the consistency of grind when the grinder is running.

The consistency of grind setting is correct if the coffee flows regularly from the coffee spout. In addition a fine, thick crema forms.

Example: Proceed as follows to change the consistency of grind during the preparation of an espresso.

- ▶ Open the storage compartment cover.
- ▶ Place a cup under the coffee spout.
- ▶ Press the Espresso button.
The grinder starts up. 1 ESPRESSO and the coffee strength are displayed.
- ▶ Turn the grinder adjustment switch to the desired position **while** the grinder is running.
The espresso is prepared and the consistency of grind is adjusted.
- ▶ Close the storage compartment cover.



2 Preparation

- i** You can stop preparation of a speciality coffee, milk speciality or hot water at any time. Just press any button.
- i** Before and during the grinding operation you can select the **coffee strength** of individual products: extra-mild (☺), mild (☺☺), normal (☺☺☺), strong (☺☺☺☺) or extra-strong (☺☺☺☺☺).
- i** During preparation, you can change the preset **amount of water** by turning the Rotary Switch.
- i** You can follow the current status of preparation on the progress bar.

You can make permanent settings for all products in programming mode (see Chapter 4 ‘Permanent settings in programming mode – Products’).

Ristretto, espresso and coffee

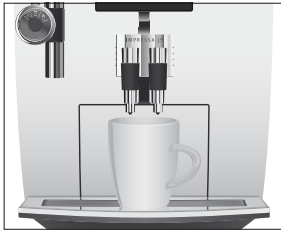

Preparation of all speciality coffees (ristretto ☺, espresso ☺ and coffee ☺) follows this model.

Example: Proceed as follows to prepare one coffee.

- ▶ Place a cup under the coffee spout.
- ☺ ▶ Press the Coffee button.

Preparation starts. **1 COFFEE** and the coffee strength is displayed. The preset amount of water for coffee flows into the cup.

Preparation stops automatically and **ENJOY** appears briefly on the display. Then **COFFEE READY** is displayed.

Preparing two speciality coffees at the touch of a button

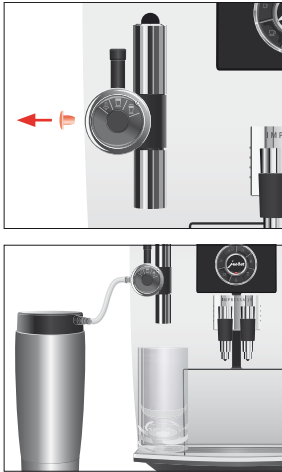

To prepare two cups of coffee: Place two cups under the coffee spout. Press the Coffee button twice ☺ (**within 2 seconds**), to start coffee preparation.

Latte macchiato, cappuccino



Your IMPRESSA can prepare a latte macchiato or cappuccino at the touch of a button. There is no need to move the glass or cup.

Example: Proceed as follows to prepare one latte macchiato.

- ▶ Remove the protective cover from the cappuccino frother.
- ▶ Attach the milk pipe to the cappuccino frother. Use the long pipe for a milk carton and the short pipe for a milk container.
- ▶ Insert the other end of the milk pipe into a milk carton or connect it to a milk container.
- ▶ Place a glass under the cappuccino frother.
- ▶ Turn the setting wheel of the cappuccino frother to the Milk Foam position .
-  ▶ Press the Latte Macchiato button.

LATTE MAC., and the coffee strength is displayed.

LATTE MAC., the milk foam is prepared.

Preparation stops automatically when the preset amount of milk is reached.

PAUSE

- i** There is a short interval while the hot milk separates from the milk foam. This allows the typical layers of a latte macchiato to form. You can choose the length of this interval in programming mode (see Chapter 4 'Permanent settings in programming mode – Products').

LATTE MAC., coffee preparation starts. The preset amount of water flows into the cup. Preparation stops automatically and ENJOY appears briefly on the display. Then COFFEE READY is displayed.

To make sure the cappuccino frother always works properly, rinse and clean it regularly (see Chapter 5 'Maintenance – Rinsing the cappuccino frother').

Warm milk and milk foam

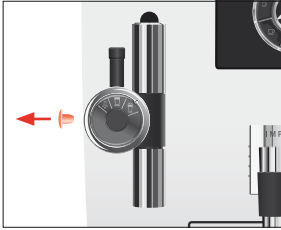



Example: Proceed as follows to prepare milk foam.

- ▶ Remove the protective cover from the cappuccino frother.
- ▶ Attach the milk pipe to the cappuccino frother. Use the long pipe for a milk carton and the short pipe for a milk container.
- ▶ Insert the other end of the milk pipe into a milk carton or connect it to a milk container.

- ▶ Place a cup under the cappuccino frother.
- ▶ Turn the setting wheel of the cappuccino frother to the Milk Foam position .

- i** If you want to **heat the milk** turn the setting wheel of the cappuccino frother to the Milk position .

-  ▶ Press the Milk button.
HEATING UP
As soon as the machine has heated up, **COFFEE READY** appears.

-  ▶ Press the Milk button again.
MILK, the milk foam is prepared. Preparation stops automatically when the preset amount of milk is reached.
COFFEE READY appears on the display.

To make sure the cappuccino frother always works properly, rinse and clean it regularly (see Chapter 5 'Maintenance – Rinsing the cappuccino frother').

Ground coffee

You can choose to use a second coffee variety, for example decaffeinated coffee, with the filter funnel for ground coffee.

- i** Never add more than two level measuring spoons of ground coffee.
- i** Use ground coffee which is not ground too finely. Very fine coffee can block up the system so that the coffee only comes out in drips.
- i** If you did not fill the machine with a sufficient amount of ground coffee, **NOT ENOUGH PRE-GROUND** is displayed and the IMPRESSA stops the operation.
- i** The desired speciality coffee must be prepared within approximately one minute after filling with the ground coffee. Otherwise the IMPRESSA stops the operation and is once more ready for use.

All speciality coffees with ground coffee are prepared following this model.

Example: Proceed as follows to prepare an espresso using ground coffee.



- ▶ Place an espresso cup under the coffee spout.
- ▶ Open the cover of the filler funnel for ground coffee.
FILL PRE-GROUND
- ▶ Place one level measuring spoon of ground coffee into the filler funnel.
- ▶ Close the cover of the filler funnel.
COFFEE READY
- ☺** ▶ Press the Espresso button.
Preparation will now begin. The preset amount of water for espresso flows into the cup. Preparation stops automatically and **ENJOY** appears briefly on the display. Then **COFFEE READY** is displayed.

Permanently setting the amount of water for the cup size

It is easy to make permanent settings for the amount of water for all speciality coffees and hot water according to the cup size. Adjust the amount once as shown in the following example. Every time you prepare a drink in the future, this amount of water will be dispensed.

The permanent settings for adapting the amount of water to the cup size for all speciality coffees and hot water follow this model.

Example: Proceed as follows to **permanently** set the amount of water for one coffee.

Precondition: COFFEE READY is displayed.

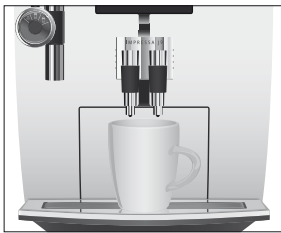

- ▶ Place a cup under the coffee spout.
- ☞ ▶ Press and **hold** the Coffee button.
1 COFFEE and the coffee strength is displayed.
- ☞ ▶ **Hold** the Coffee button down until ENOUGH COFFEE? appears.
- ▶ Release the Coffee button.
Preparation starts and the coffee flows into the cup.
- ▶ Press any button as soon as there is sufficient coffee in the cup.
Preparation stops. CONFIRMED and ENJOY appear briefly on the display. The set amount of water for one coffee is permanently stored. COFFEE READY appears on the display.

- i** You can alter this setting at any time by repeating the above procedure.
- i** You can also permanently set the amount for all specialty coffees and hot water in the programming mode (see Chapter 4 ‘Permanent settings in programming mode – Products’).

Hot water

To obtain a perfect water flow, use the hot-water nozzle. You can find the hot-water nozzle under the cover of the storage compartment.

The following temperatures can be selected for preparing hot water: **LOW, NORMAL, X HIGH**.

⚠ CAUTION

There is a danger of scalding from hot water splashes.

- ▶ Avoid direct contact with the skin.
-
- ▶ Carefully pull the cappuccino frother down and off.
 - ▶ Open the storage compartment cover, take out the hot-water nozzle and close the cover again.
 - ▶ Attach the hot-water nozzle to the connector.
 - ▶ Place a cup under the hot-water nozzle.
 - ▶ Press the Hot Water button.
The temperature is displayed.

- i** By touching the Hot Water button several times (**within approximately 2 seconds**) you can set the temperature to your individual preference. This setting is not saved.

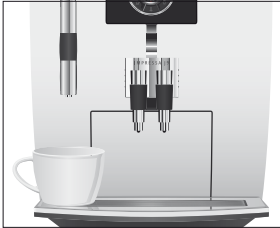

WATER, hot water flows into the cup. Preparation stops automatically and **COFFEE READY** appears on the display.



3 Daily operation

Switching on

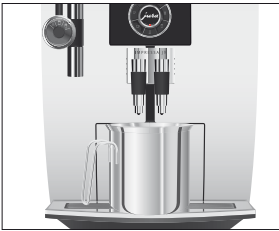
When the IMPRESSA is switched on, it automatically prompts you to perform the rinse operation. Start the rinse operation by pressing the Maintenance button . In programming mode you can change this setting so that the machine starts the switch-on rinse automatically (see Chapter 4 ‘Permanent settings in programming mode – Rinses’).



Precondition: Your IMPRESSA is switched on at the power switch.

- ▶ Place a receptacle under the coffee spout.
-  ▶ Press the On/Off button to switch the IMPRESSA on.
WELCOME TO JURA appears on the display.
HEATING UP
PRESS RINSE, the Maintenance button  lights up.

-  ▶ Press the Maintenance button.
MACHINE RINSING, the machine rinses.

The operation stops automatically and **COFFEE READY** appears on the display.

Daily maintenance

To ensure that you get many years of reliable service out of your IMPRESSA and to guarantee the optimum coffee quality, the machine requires daily maintenance.

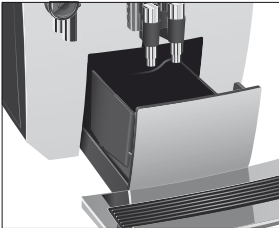

- ▶ Pull out the drip tray.
- ▶ Empty the coffee grounds container and the drip tray. Rinse them both with warm water.
- ▶ Dry the metal contacts on the back of the drip tray.
- ▶ Refit the coffee grounds container and the drip tray.
- ▶ Rinse the water tank with clean water.
- ▶ Dismantle and rinse the cappuccino frother (see Chapter 5 ‘Maintenance – Rinsing the cappuccino frother’).
- ▶ Wipe the surface of the machine with a clean, soft, damp cloth (e.g. microfibre cloth).

Switching off

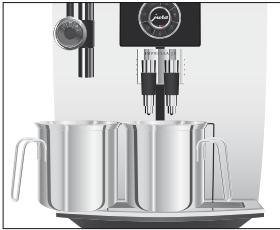

When you switch your IMPRESSA off, the spouts used to prepare a speciality coffee or milk are rinsed.

- ▶ Place one receptacle under the coffee spout and another under the cappuccino frother.
- ▶ Press the On/Off button.

MACHINE RINSING, the spouts used to prepare a speciality coffee or milk are rinsed. The operation stops automatically and your IMPRESSA is switched off.

- i** When the IMPRESSA is switched off with the On/Off button, the machine consumes less than 0.1 W of standby energy. The machine can be completely disconnected from the power supply using the power switch.

4 Permanent settings in programming mode

You can make permanent settings in programming mode. You can navigate through the programme items and permanently save the required settings simply by turning and pressing the Rotary Switch. You can make the following settings with the Rotary Switch:

Programme item	Sub-item	Explanation
MAINTENANCE	CLEAN CAPPUCCINO, RINSE MACHINE, RINSE CAPPUCCINO, CLEAN MACHINE, DECALCIFY MACHINE (only if filter is not activated), CHANGE FILTER (only if filter is activated)	▶ Select the desired maintenance programme. If no action is taken in this programme item, programming mode is exited automatically after approximately 5 seconds.
PRODUCTS	SELECT PRODUCT	▶ Select your settings for speciality coffees, milk specialities and hot water.
FILTER	YES, NO	▶ Indicate whether you are operating your IMPRESSA with or without a CLARIS Blue filter cartridge.
HARDNESS (only if filter is not activated)	HARDNESS INACTIVE, 1 °dH – 30 °dH	▶ Adjust the water hardness.
ECONOMY MODE	SAVE YES, SAVE NO	▶ Select an energy-saving mode.
OFF AFTER	15 MIN., 0.5 H – 15 H	▶ Set the time after which the IMPRESSA should switch off automatically.
RINSES	INIT RINSE, CAPP RINSE	▶ Change the settings for the switch-on rinse and the cappuccino rinse.
RESET	PRODUCT, ALL PRODUCTS, RESET ALL	▶ Reset the permanently set values of all products to the factory settings.
INFORMATION		▶ Keep track of all prepared speciality coffees and milk specialities and view the maintenance status.
SETTINGS	ML, OZ	▶ Select the unit for the amount of water.

Programme item	Sub-item	Explanation
SYMBOL BRIGHTNESS	BRIGHTNESS	► Adjust the brightness of the symbols.
LANGUAGE		► Select your language.
EXIT		► Exit programming mode.

Products

In the programme item **PRODUCTS** you can make individual settings for all speciality coffees and hot water. The following permanent settings can be made:

Product	Temperature	Coffee strength	Amount
1 ristretto, 1 espresso, 1 coffee	NORMAL, HIGH	☉ (extra-mild), ☉☉ (mild), ☉☉☉ (normal), ☉☉☉☉ (strong), ☉☉☉☉☉ (extra-strong)	Amount of water: 25 ML - 240 ML
2 ristretti, 2 espressi, 2 coffees	NORMAL, HIGH	-	Amount of water: 25 ML - 240 ML (per cup)
Latte macchiato, cappuccino	NORMAL, HIGH	☉ (extra-mild), ☉☉ (mild), ☉☉☉ (normal), ☉☉☉☉ (strong), ☉☉☉☉☉ (extra-strong)	Amount of milk: 3 SEC - 120 SEC Interval: 0 SEC - 60 SEC Amount of water: 25 ML - 240 ML
Milk	-	-	3 SEC - 120 SEC
Hot water	LOW, NORMAL, X HIGH	-	25 ML - 450 ML



Permanent settings in programming mode always follow the same model.



Example: Proceed as follows to change the amount of milk for a latte macchiato from 16 SEC to 20 SEC, the amount of water from 45 ML to 40 ML and the interval from 30 SEC to 20 SEC.

















Precondition: COFFEE READY is displayed.

- ⏻ ► Press and hold the Rotary Switch until MAINTENANCE appears.

4 Permanent settings in programming mode

-  ▶ Turn the Rotary Switch until **PRODUCTS** is displayed.
-  ▶ Press the Rotary Switch to enter the programme item.
SELECT PRODUCT

-  Next select the button of the product for which you would like to make settings. No product is prepared at this point.
-  To change the setting for a double product, press the corresponding symbol twice within 2 seconds.

-  ▶ Press the Latte Macchiato button.
COFFEE 45 ML
-  ▶ Press the Rotary Switch to enter the programme item.
COFFEE 45 ML
-  ▶ Turn the Rotary Switch until **COFFEE 40 ML** is displayed.
-  ▶ Press the Rotary Switch to confirm the setting.
CONFIRMED appears briefly on the display.
COFFEE 40 ML
-  ▶ Turn the Rotary Switch until **MILK 16 SEC** is displayed.
-  ▶ Press the Rotary Switch to enter the programme item.
MILK 16 SEC
- ▶ Turn the Rotary Switch until **MILK 20 SEC** is displayed.
-  ▶ Press the Rotary Switch to confirm the setting.
CONFIRMED appears briefly on the display.
MILK 20 SEC
-  ▶ Turn the Rotary Switch until **PAUSE 30 SEC** is displayed.
-  ▶ Press the Rotary Switch to enter the programme item.
PAUSE 30 SEC
-  ▶ Turn the Rotary Switch until **PAUSE 20 SEC** is displayed.
-  ▶ Press the Rotary Switch to confirm the setting.
CONFIRMED appears briefly on the display.
PAUSE 20 SEC
-  ▶ Turn the Rotary Switch until **EXIT** is displayed.
-  ▶ Press the Rotary Switch to exit the programme item.
SELECT PRODUCT
-  ▶ Turn the Rotary Switch until **EXIT** is displayed.
-  ▶ Press the Rotary Switch to exit the programme item.
PRODUCTS
-  ▶ Turn the Rotary Switch until **EXIT** is displayed.

- ▶ Press the Rotary Switch to exit the programme item.
COFFEE READY

Energy-saving mode

In the programme item **ECONOMY MODE** you can permanently set an energy-saving mode (Energy Save Mode, E.S.M.[®]):

- **SAVE NO**
 - All speciality coffees, speciality coffees with milk and hot water can be prepared without having to wait.
 - Before milk preparation, the machine heats up.
- **SAVE YES** (Energy saving of up to 40%)
 - Soon after the last preparation, the IMPRESSA stops heating up. As soon as the energy-saving temperature is reached, this is indicated in the display by the message **ENERGY ON** – this may last several minutes.
 - The machine starts up before coffee, hot water or milk preparation.

Example: Proceed as follows to change the energy-saving mode from **SAVE NO** to **SAVE YES**.

Precondition: **COFFEE READY** is displayed.

- ▶ Press **and hold** the Rotary Switch until **MAINTENANCE** appears.
- ▶ Turn the Rotary Switch until **ECONOMY MODE –** is displayed.
- ▶ Press the Rotary Switch to enter the programme item.
SAVE NO
- ▶ Turn the Rotary Switch until **SAVE YES** is displayed.
- ▶ Press the Rotary Switch to confirm the setting.
CONFIRMED appears briefly on the display.
ECONOMY MODE ✓
- ▶ Turn the Rotary Switch until **EXIT** is displayed.
- ▶ Press the Rotary Switch to exit programming mode.
COFFEE READY







Automatic switch-off

By instructing your IMPRESSA to automatically switch itself off, you can cut down your energy consumption. If this function is activated, your IMPRESSA switches off automatically after the preset time following the last action on the machine.

You can set the automatic switch-off time to 15 minutes or 0.5–15 hours.

Example: Proceed as follows to change the automatic switch-off from **2 H** to **15 MIN.**.

Precondition: **COFFEE READY** is displayed.

-  ▶ Press **and hold** the Rotary Switch until **MAINTENANCE** appears.
-  ▶ Turn the Rotary Switch until **OFF AFTER 2 H** is displayed.
-  ▶ Press the Rotary Switch to enter the programme item.
OFF AFTER 2 H
-  ▶ Turn the Rotary Switch until **OFF AFTER 15 MIN.** is displayed.
-  ▶ Press the Rotary Switch to confirm the setting.
CONFIRMED appears briefly on the display.
OFF AFTER 15 MIN.
-  ▶ Turn the Rotary Switch until **EXIT** is displayed.
-  ▶ Press the Rotary Switch to exit programming mode.
COFFEE READY

Rinses

In the programme item **RINSES** you can make the following settings:

- **INIT RINSE MANUAL**
 - The switch-on rinse must be started manually.
- **INIT RINSE AUTO**
 - The switch-on rinse is started automatically.
- **CAPP RINSE AFTER 10'**
 - You are prompted to perform a cappuccino rinse 10 minutes after preparation of a speciality coffee with milk.
- **CAPP RINSE NOW**
 - You are prompted to perform a cappuccino rinse immediately after preparation of a speciality coffee with milk.

Example: Proceed as follows to make the machine prompt you to perform the cappuccino rinse **immediately** after preparing a speciality coffee with milk.

Precondition: `COFFEE READY` is displayed.

- ⌚ ▶ Press **and hold** the Rotary Switch until `MAINTENANCE` appears.
- ⌚ ▶ Turn the Rotary Switch until `RINSES` is displayed.
- ⌚ ▶ Press the Rotary Switch to enter the programme item.
`INIT RINSE MANUAL`
- ⌚ ▶ Turn the Rotary Switch until `CAPP RINSE AFTER 10'` is displayed.
- ⌚ ▶ Press the Rotary Switch to enter the programme item.
`CAPP RINSE AFTER 10'`
- ⌚ ▶ Turn the Rotary Switch until `CAPP RINSE NOW` is displayed.
- ⌚ ▶ Press the Rotary Switch to confirm the setting.
`CONFIRMED` appears briefly on the display.
`CAPP RINSE NOW`
- ⌚ ▶ Turn the Rotary Switch until `EXIT` is displayed.
- ⌚ ▶ Press the Rotary Switch.
`RINSES`
- ⌚ ▶ Turn the Rotary Switch until `EXIT` is displayed.
- ⌚ ▶ Press the Rotary Switch to exit programming mode.
`COFFEE READY`









Restore factory settings

In the programme item `RESET` you can reset various settings to their factory settings:

- `PRODUCT`
 - The settings (amount of water, aroma, temperature etc.) for any product can be reset **individually** to the factory settings. The corresponding double product is also reset to the factory settings at the same time.
- `ALL PRODUCTS`
 - The settings (amount of water, aroma, temperature etc.) for **all products** are reset to the factory settings.
- `RESET ALL`
 - **All customer settings** (apart from the 'filter') are reset to factory settings. Your IMPRESSA then switches off.

Example: Proceed as follows to reset the values for 'Espresso' to the factory settings.

Precondition: COFFEE READY is displayed.





-  ▶ Press **and hold** the Rotary Switch until MAINTENANCE appears.
-  ▶ Turn the Rotary Switch until RESET is displayed.
-  ▶ Press the Rotary Switch to enter the programme item.
PRODUCT
-  ▶ Press the Espresso button.
CONFIRMED appears briefly on the display. The settings for 'Espresso' are reset to the factory settings.
PRODUCT
-  ▶ Turn the Rotary Switch until EXIT is displayed.
-  ▶ Press the Rotary Switch to exit the programme item.
RESET
-  ▶ Turn the Rotary Switch until EXIT is displayed.
-  ▶ Press the Rotary Switch to exit programming mode.
COFFEE READY





Viewing information and maintenance status

In the programme item INFORMATION you can view the following information:

- Number of prepared coffee speciality coffees, speciality coffees with milk and hot water
- Maintenance status and number of maintenance programmes performed (cleaning, descaling, changing the filter)
- Number of cappuccino frother cleaning operations performed
- Software version

Precondition: COFFEE READY is displayed.

-  ▶ Press **and hold** the Rotary Switch until MAINTENANCE appears.
-  ▶ Turn the Rotary Switch until INFORMATION is displayed.
-  ▶ Press the Rotary Switch to enter the programme item.
TOTAL, the total number of prepared speciality coffees and milk specialities is displayed.
-  ▶ Turn the Rotary Switch to view additional information.







-  The maintenance status can also be displayed in addition to the number of performed maintenance programmes. The bar shows the current maintenance status. When the bar is completely filled, your IMPRESSA will request the respective maintenance programme.
-  ▶ Press the Rotary Switch to exit the programme item.
INFORMATION
-  ▶ Turn the Rotary Switch until EXIT is displayed.
-  ▶ Press the Rotary Switch to exit programming mode.
COFFEE READY

Unit for amount of water

You can change the unit for the amount of water from 'ml' to 'oz'.

Example: Proceed as follows to change the unit for the amount of water from ML to OZ.



Precondition: COFFEE READY is displayed.

-  ▶ Press **and hold** the Rotary Switch until MAINTENANCE appears.
-  ▶ Turn the Rotary Switch until SETTINGS ML is displayed.
-  ▶ Press the Rotary Switch to enter the programme item.
SETTINGS ML
-  ▶ Turn the Rotary Switch until SETTINGS OZ is displayed.
-  ▶ Press the Rotary Switch to confirm the setting.
CONFIRMED appears briefly on the display.
SETTINGS OZ
-  ▶ Turn the Rotary Switch until EXIT is displayed.
-  ▶ Press the Rotary Switch to exit programming mode.
COFFEE READY





Brightness of symbols

You can individually adjust the brightness of the symbols.

Precondition: COFFEE READY is displayed.

-  ▶ Press **and hold** the Rotary Switch until MAINTENANCE appears.
-  ▶ Turn the Rotary Switch until SYMBOL BRIGHTNESS is displayed.
-  ▶ Press the Rotary Switch to enter the programme item.
BRIGHTNESS

4 Permanent settings in programming mode







-  ▶ Turn the Rotary Switch to set the required brightness of the symbols.
-  ▶ Press the Rotary Switch to confirm the setting.
`CONFIRMED` appears briefly on the display.
`SYMBOL BRIGHTNESS`
-  ▶ Turn the Rotary Switch until `EXIT` is displayed.
-  ▶ Press the Rotary Switch to exit programming mode.
`COFFEE READY`

Language

In this programme item you can set the language used by your IMPRESSA.

Example: Proceed as follows to change the language from `ENGLISH` to `DEUTSCH`.

Precondition: `COFFEE READY` is displayed.

-  ▶ Press **and hold** the Rotary Switch until `MAINTENANCE` appears.
-  ▶ Turn the Rotary Switch until `LANGUAGE ENGLISH` is displayed.
-  ▶ Press the Rotary Switch to enter the programme item.
`LANGUAGE ENGLISH`
-  ▶ Turn the Rotary Switch until `SPRACHE DEUTSCH` is displayed.
-  ▶ Press the Rotary Switch to confirm the setting.
`GESPEICHERT` appears briefly on the display.
`SPRACHE DEUTSCH`
-  ▶ Turn the Rotary Switch until `EXIT` is displayed.
-  ▶ Press the Rotary Switch to exit programming mode.
`BITTE WAHLEN`

5 Maintenance

Your IMPRESSA has the following integrated maintenance programmes:

- Cleaning the cappuccino frother (CLEAN CAPPUCCINO)
- Rinsing the cappuccino frother (RINSE CAPPUCCINO)
- Changing the filter (CHANGE FILTER)
- Cleaning the machine (CLEAN MACHINE)
- Rinsing the machine (RINSE MACHINE)
- Descaling the machine (DECALCIFY MACHINE)

i Clean or descale the machine or change the filter when the display prompts you to do so.

Rinsing the machine

You can initiate the rinse operation manually at any time.



Precondition: COFFEE READY is displayed.

- ▶ Place a receptacle under the coffee spout.
- ▶ Press **and hold** the Rotary Switch until MAINTENANCE appears.
- ▶ Press the Rotary Switch to enter the programme item. CLEAN CAPPUCCINO
- ▶ Turn the Rotary Switch until RINSE MACHINE is displayed.
- ▶ Press the Rotary Switch to initiate the rinse operation. MACHINE RINSING

The rinse stops automatically and COFFEE READY appears on the display.

Rinsing the cappuccino frother

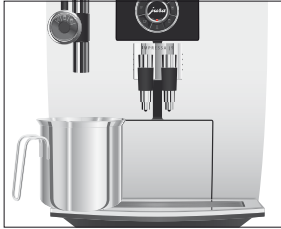

After each milk preparation, the IMPRESSA prompts you to run a cappuccino rinse.

Precondition: **COFFEE READY / RINSE CAPPUCCINO** is displayed and the Maintenance button  lights up.

- ▶ Place a receptacle under the cappuccino frother.
-  ▶ Press the Maintenance button.

CAFFU. RINSING, the cappuccino frother is rinsed.

The operation stops automatically and **COFFEE READY** appears on the display.

Cleaning the cappuccino frother

To ensure that the cappuccino frother always works properly, you should clean it **daily** when you have been preparing milk. Your IMPRESSA will **not** prompt you to clean the cappuccino frother.





CAUTION

If the wrong cleaning agent is used, the machine could be damaged and/or traces could be left behind in the water.

- ▶ Use only original JURA maintenance products.

 JURA Cappuccino Cleaner is available from stockists.

Precondition: **COFFEE READY** is displayed.

-  ▶ Press **and hold** the Rotary Switch until **MAINTENANCE** appears.
-  ▶ Press the Rotary Switch to enter the programme item.
CLEAN CAPPUCCINO
-  ▶ Press the Rotary Switch.
CLEANER FOR CAPPU.
 - ▶ Pour 250 ml of fresh water into a receptacle and add one capful (max. 15 ml) of Cappuccino Cleaner.
 - ▶ Immerse the milk pipe in the receptacle.
 - ▶ Turn the setting wheel of the cappuccino frother to the Milk Foam  or Milk  position.

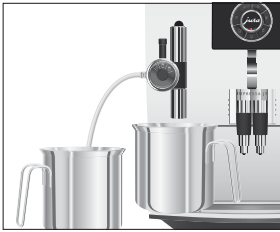

- ▶ Place another receptacle under the cappuccino frother.
- ⚠ ▶ Press the Maintenance button.
CAPPUCCINO CLEANS, the cappuccino frother and the pipe are cleaned.
WATER FOR CAPPUCCINO
- ▶ Rinse the receptacle thoroughly, fill it with 250 ml of fresh water and immerse the milk pipe in the water.
- ▶ Empty the other receptacle and place it under the cappuccino frother again.
- ⚠ ▶ Press the Maintenance button.
CAPPUCCINO CLEANS, the cappuccino frother and the pipe are rinsed with fresh water.
COFFEE READY appears on the display.

Dismantling and rinsing the cappuccino frother



- ▶ Carefully pull the cappuccino frother down and off.
 - ▶ Dismantle the cappuccino frother into its individual parts.
 - ▶ Rinse all parts of the cappuccino frother thoroughly under running water.
 - ▶ Reassemble the cappuccino frother.
- i** Ensure that all individual parts are correctly and firmly connected to ensure correct operation of the cappuccino frother.
- ▶ Firmly attach it to the connector.

Changing the filter

- i** After 50 litres of water have flowed through, the filter will cease to work. Your IMPRESSA will automatically prompt you to change the filter.
- i** After two months, the filter will cease to work. You can check the elapsed time by referring to the date plate on the filter holder in the water tank.
- i** If the CLARIS Blue filter cartridge is not activated in programming mode, you will not be prompted to change the filter.

Precondition: COFFEE READY / CHANGE FILTER is displayed and the Maintenance button  lights up.

-  ▶ Press the Maintenance button.

DURATION 2 MIN. / START YES

-  If you do not want to start changing the filter just yet, turn the Rotary Switch until START NO is displayed. Press the Rotary Switch to exit the maintenance programme. The prompt to ‘change the filter’ remains active.

-  ▶ Press the Maintenance button.

CHANGE FILTER / PRESS RINSE



- ▶ Remove and empty the water tank.
- ▶ Open the filter holder and remove the old CLARIS Blue filter cartridge and filter extension.
- ▶ Fit the filter extension on top of a new filter cartridge.
- ▶ Insert the filter cartridge into the water tank, exerting slight pressure.
- ▶ Close the filter holder. It will click into place audibly.
- ▶ Fill the water tank with fresh, cold water and reinsert the tank.



- ▶ Place a receptacle (at least 500 ml) under the cappuccino frother.
- ▶ Turn the setting wheel of the cappuccino frother to the Steam position .

-  ▶ Press the Maintenance button.

FILTER RINSING, water flows out of the cappuccino frother.

-  You can interrupt rinsing of the filter at any time by pressing any button. Press the Maintenance button , to continue with rinsing of the filter.

-  The water may be slightly discoloured. This is not harmful to health and does not affect the taste.

Rinsing of the filter stops automatically after approximately 500 ml. The IMPRESSA heats up and is once more ready for use.

Cleaning the machine

After 200 preparations or 80 switch-on rinses, the IMPRESSA will prompt you to clean it.

CAUTION

If the wrong cleaning agent is used, the machine could be damaged and/or traces could be left behind in the water.

- ▶ Use only original JURA maintenance products.

- i** The cleaning programme lasts approximately 20 minutes.
- i** Do not interrupt the cleaning programme. The quality of cleaning will be impaired if you do so.
- i** JURA cleaning tablets are available from stockists.

Precondition: COFFEE READY / CLEAN MACHINE is displayed and the Maintenance button  lights up.

-  ▶ Press the Maintenance button.

DURATION 20 MIN. / START YES

- i** If you do not want to start cleaning just yet, turn the Rotary Switch until START NO is displayed. Press the Rotary Switch to exit the maintenance programme. The prompt to 'clean the machine' remains active.

-  ▶ Press the Maintenance button.

EMPTY TRAY

- ▶ Empty the drip tray and coffee grounds container and put them back into the machine.

PRESS RINSE, the Maintenance button  lights up.

- ▶ Place one receptacle under the coffee spout and another under the cappuccino frother.

-  ▶ Press the Maintenance button.



CLEANS, water flows out of the coffee spout.

The operation is interrupted, ADD TABLET.

- ▶ Open the cover of the filler funnel for ground coffee.





- ▶ Insert a JURA cleaning tablet into the filler funnel.
- ▶ Close the cover of the filler funnel.
ADD TABLET / PRESS RINSE, the Maintenance button  lights up.
-  ▶ Press the Maintenance button.
CLEANS, water flows repeatedly out of the coffee spout and the cappuccino frother.
The operation is interrupted, **EMPTY TRAY**.
- ▶ Empty the drip tray and coffee grounds container and put them back into the machine.
Cleaning is now complete. The IMPRESSA heats up and is once more ready for use.

Descaling the machine



The IMPRESSA builds up deposits of limescale over time and automatically prompts you to descale it when necessary. The degree of calcification depends on the hardness of your water.

-  **CAUTION** If the descaling agent comes into contact with the skin or eyes, this can cause irritation.
- ▶ Avoid contact with the skin or eyes.
 - ▶ Rinse off descaling agent with clean water. Should you get any descaling agent in your eye, see a doctor.

- CAUTION** If the wrong descaling agent is used, the machine could be damaged and/or traces could be left behind in the water.
- ▶ Use only original JURA maintenance products.

- CAUTION** If the descaling operation is interrupted, there may be damage to the machine.
- ▶ Allow the descaling programme to run to the end.

- CAUTION** If the descaling agent comes into contact with sensitive surfaces (e.g. marble), damage cannot be ruled out.
- ▶ Clean up any splashes immediately.

-  The descaling programme lasts approximately 45 minutes.
-  JURA descaling tablets are available from stockists.
-  If you use a CLARIS Blue filter cartridge and this is activated, you will not be prompted to descale.

Precondition: COFFEE READY / DECALCIFY MACHINE is displayed and the Maintenance button ☸ lights up.

- ☸ ▶ Press the Maintenance button.

DURATION 45 MIN. / START YES

- i If you do not want to start descaling just yet, turn the Rotary Switch until START NO is displayed. Press the Rotary Switch to exit the maintenance programme. The prompt to 'descale the machine' remains active.

- ☸ ▶ Press the Maintenance button.

EMPTY TRAY

- ▶ Empty the drip tray and coffee grounds container and put them back into the machine.

SOLVENT IN TANK

- ▶ Remove and empty the water tank.
- ▶ Completely dissolve the contents of one blister (three JURA descaling tablets) in a receptacle holding 500 ml of water. This may take several minutes.
- ▶ Pour the solution into the empty water tank and insert it into the machine.

SOLVENT IN TANK / PRESS RINSE, the Maintenance button ☸ lights up.

- ▶ Remove the cappuccino frother.
- ▶ Place a receptacle (at least 500 ml) under the connector of the cappuccino frother.

- ☸ ▶ Press the Maintenance button.

DECALOS

Water flows repeatedly out of the connector of the cappuccino frother. The Maintenance button ☸ flashes during the descaling operation.

The operation stops automatically, EMPTY TRAY.



- ▶ Empty the receptacle under the connector of the cappuccino frother.
- ▶ Empty the drip tray and coffee grounds container and put them back into the machine.

RINSE WATER TANK / FILL WATER TANK

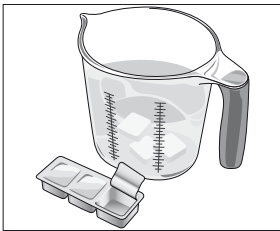
- ▶ Remove the water tank and rinse it thoroughly.







- ▶ Fill the water tank with fresh, cold water and reinsert the tank.
PRESS RINSE, the Maintenance button  lights up.
- ▶ Refit the cappuccino frother.
- ▶ Place a receptacle under the cappuccino frother and another under the coffee spout.
-  ▶ Press the Maintenance button.
DESCALING, water flows out of the cappuccino frother and the coffee spout.
HEATING UP, MACHINE RINSING, water flows out of the coffee spout.
The operation stops automatically, **EMPTY TRAY**.
- ▶ Empty the drip tray and coffee grounds container and put them back into the machine.
Descaling is now complete. The IMPRESSA is once more ready for use.

 If the descaling operation stops unexpectedly, rinse the water tank thoroughly.

Cleaning the bean container

Coffee beans may be covered with a slight oil film which remains on the walls of the bean container. These traces may negatively affect the coffee result. For this reason clean the bean container from time to time.

Precondition: **COFFEE READY / FILL BEANS** is displayed.

-  ▶ Switch the machine off with the On/Off button.
-  ▶ Switch the machine off at the power switch.
- ▶ Open the bean container cover and remove the aroma preservation cover.
- ▶ Clean the bean container with a soft, dry cloth.
- ▶ Fill the bean container with coffee beans, then close the aroma preservation cover and the bean container cover.

Descaling the water tank

Limescale deposits may form in the water tank. To ensure correct function of the machine, descale the water tank from time to time.

- ▶ Remove the water tank.
- ▶ If you use a CLARIS Blue filter cartridge, remove this.
- ▶ Descale the tank with a mild conventional descaling agent in accordance with the manufacturer's instructions.
- ▶ Rinse out the water tank thoroughly.
- ▶ If you use a CLARIS Blue filter cartridge, insert this again.
- ▶ Fill the water tank with fresh, cold water and reinsert the tank.

6 Display messages

Message	Cause/Result	Action
FILL WATER TANK	The water tank is empty. You cannot prepare any products.	► Fill the water tank (see Chapter 1 'Preparing and using for the first time – Filling the water tank').
EMPTY GROUNDS	The coffee grounds container is full. You cannot prepare any speciality coffees, but you can prepare hot water and milk.	► Empty the coffee grounds container and the drip tray (see Chapter 3 'Daily operation – Daily maintenance').
EMPTY TRAY	The drip tray is full. You cannot prepare any products.	► Empty the drip tray. ► Clean and dry the metal contacts on the back of the drip tray.
TRAY MISSING	The drip tray is not inserted correctly or is not inserted at all. You cannot prepare any products.	► Fit the drip tray.
PRESS RINSE	The IMPRESSA is prompting you to perform a rinse or continue a maintenance programme that was already started.	► Press the Maintenance button to start the rinse or to continue the maintenance programme.
FILL BEANS	The bean container is empty. You cannot prepare any speciality coffees, but you can prepare hot water and milk.	► Fill the bean container (see Chapter 1 'Preparing and using for the first time – Filling the bean container').
COFFEE READY / RINSE CAPPUCCINO	The IMPRESSA requests a cappuccino rinse.	► Press the Maintenance button to start the cappuccino rinse.
COFFEE READY / CLEAN MACHINE or COFFEE READY / CLEAN NOW	The IMPRESSA is prompting you to clean it.	► Perform cleaning (see Chapter 5 'Maintenance – Cleaning the machine').

Message	Cause/Result	Action
COFFEE READY / DECALCIFY MACHINE or COFFEE READY / DECALCIFY NOW	The IMPRESSA is prompting you to descale it.	► Perform descaling (see Chapter 5 'Maintenance – Descaling the machine').
COFFEE READY / CHANGE FILTER or COFFEE READY / CHANGE NOW	The filter cartridge no longer works.	► Replace the CLARIS Blue filter cartridge (see Chapter 5 'Maintenance – Changing the filter').
NOT ENOUGH PRE-GROUND	There is insufficient ground coffee in the machine; the IMPRESSA stops the operation.	► The next time you prepare a beverage, add more preground coffee (see Chapter 2 'Preparation – Ground coffee').
FILL SYSTEM / PRESS RINSE	The system must be filled with water. You cannot prepare any products.	► Place a receptacle under the cappuccino frother and press the Maintenance button  .

7 Troubleshooting

Problem	Cause/Result	Action
When preparing a latte macchiato, the typical three layers do not form.	–	<ul style="list-style-type: none"> ▶ Turn the setting wheel of the cappuccino to the far right and the Milk Foam position . ▶ Change the length of the interval to at least 30 seconds (see Chapter 4 'Permanent settings in programming mode – Products') in the programming mode.
Insufficient foam is produced when the milk is frothed or milk sprays from the cappuccino frother.	The cappuccino frother is dirty.	▶ Rinse and clean the cappuccino frother.
Coffee only comes out in drips when it is being prepared.	Coffee or ground coffee has been ground too finely and is blocking the system. The same filter cartridge may have been used several times or the water hardness set incorrectly in the programming mode.	<ul style="list-style-type: none"> ▶ Put the grinder on a coarser setting or use coarser ground coffee (see Chapter 1 'Preparing and using for the first time – Adjusting the grinder'). ▶ Perform descaling (see Chapter 5 'Maintenance – Descaling the machine').
Water hardness cannot be adjusted.	The CLARIS Blue filter cartridge is activated.	▶ Deactivate the filter cartridge in programming mode.
FILL BEANS is not displayed although the bean container is empty.	The bean monitor is dirty.	▶ Clean the bean container (see Chapter 5 'Maintenance – Cleaning the bean container').
EMPTY TRAY is always displayed.	The metal contacts of the drip tray are dirty or wet.	▶ Clean and dry the metal contacts on the back of the drip tray.
FILL WATER TANK is displayed although the water tank is full.	The water tank float is trapped.	▶ Descale the water tank (see Chapter 5 'Maintenance – Descaling the water tank').

Problem	Cause/Result	Action
Little or no water or steam comes out of the cappuccino frother. The pump is very quiet.	The connector of the cappuccino frother may be blocked by milk residues or limescale fragments loosened during descaling.	<ul style="list-style-type: none"> ▶ Remove the cappuccino frother. ▶ Unscrew the black connector with the aid of the hexagonal hole on the measuring spoon for ground coffee. ▶ Clean the connector thoroughly. ▶ Screw the connector back on by hand. ▶ Carefully tighten it using the hexagonal hole on the measuring spoon, turning by no more than a quarter of a rotation.
Grinder is making a very loud noise.	There are foreign objects in the grinder.	▶ Contact customer support in your country (see Chapter 11 'JURA contact details / Legal information').
ERROR 2 is displayed.	If the machine was exposed to the cold for a long period of time, heating is disabled for safety reasons.	▶ Warm the machine at room temperature.
Other ERROR messages are displayed.	–	▶ Switch the IMPRESSA off at the power switch. Contact customer support in your country (see Chapter 11 'JURA contact details / Legal information').

i If you were unable to solve the problem, contact customer support in your country (see Chapter 11 'JURA contact details / Legal information').

8 Transport and environmentally friendly disposal

Transport / Emptying the system

In order to protect the IMPRESSA from frost during transport, the system must be emptied.

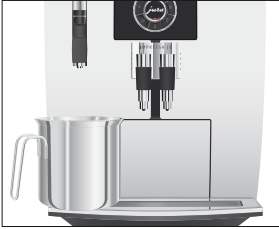

Precondition: **COFFEE READY** is displayed.

- ▶ Carefully pull the cappuccino frother down and off.
- ▶ Place a receptacle under the connector of the cappuccino frother.
- ▶ Press the Milk button.

HEATING UP

As soon as the machine has heated up, **COFFEE READY** appears.

- ▶ Press the Milk button again.

MILK, hot steam emerges from the connector.

- ▶ Remove and empty the water tank.

- ▶ Turn the Rotary Switch until **MILK 60 SEC** is displayed. Steam will continue to be discharged from the connector until the system is empty.

FILL WATER TANK

- ▶ Press the On/Off button. The IMPRESSA is switched off.

Disposal

Please dispose of old machines in an environmentally neutral way.



Old machines contain valuable, recyclable materials which should be recycled. Please therefore dispose of old machines via suitable collection systems.

9 Technical data

Voltage	220–240 V ~, 50 Hz
Power	1450 W
Safety test	Ⓢ
Energy consumption SAVE YES	Approx. 5 Wh
Energy consumption SAVE NO	Approx. 12 Wh
Pump pressure	Static, max. 15 bar
Holding capacity of water tank	2.1 l
Holding capacity of bean container	250 g
Holding capacity of coffee grounds container	Max. 16 portions
Cable length	Approx. 1.1 m
Weight	10.9 kg
Dimensions (W × H × D)	28.5 × 34.2 × 43.3 cm

10 Index

A

- Addresses 48
- Automatic switch-off 26

B

- Bean container
 - Bean container with aroma preservation cover 4
 - Cleaning 38
 - Filling 9
- Bus bar
 - Technical data 45
- Button
 - Cappuccino button 5
 - Coffee button 5
 - Espresso button 5
 - Hot Water button 5
 - Latte Macchiato button 5
 - Maintenance button 5
 - Milk button 5
 - On/Off button 5
 - Ristretto button 5

C

- Cappuccino 15
- Cappuccino frother
 - Cleaning 32
 - Rinsing 32
- CLARIS Blue filter cartridge
 - Changing 33
 - Inserting and activating the filter 11
- Cleaning
 - Bean container 38
 - Cappuccino frother 32
 - Machine 35
- Coffee 14
- Coffee grounds container 4
- Coffee spout
 - Height- and width-adjustable coffee spout 4
- Consistency of grind
 - Adjusting the grinder 13
 - Grinder adjustment switch 4
- Contact details 48

Cover

- Bean container 4
- Cup platform 4
- Customer support 48

D

- Degree of water hardness 12
- Descaling
 - Machine 36
 - Water tank 39
- Determining and adjusting the water hardness 12
- Display 5
- Display messages 40
- Drip tray 4

E

- Emptying the system 44
- Energy-saving mode 25
- Errors
 - Troubleshooting 42
- Espresso 14

F

- Factory settings
 - Restore factory settings 27
- Filler funnel
 - Filler funnel for ground coffee 4
- Filling
 - Bean container 9
 - Water tank 9
- Filter
 - Changing 33
 - Inserting and activating the filter 11
- First-time use 10
- Frother
 - Cappuccino frother 4

G

- Ground coffee 16

H

- Hotline 48
- Hot water 18
- Hot-water nozzle 4

- I**
 - Instant coffee
 - Ground coffee 16
 - Internet 9
- J**
 - JURA
 - Contact details 48
 - Internet 9
- L**
 - Language 30
 - Latte macchiato 15
- M**
 - Machine
 - Cleaning 35
 - Descaling 36
 - Rinsing 31
 - Setting up 9
 - Switching off 21
 - Switching on 20
 - Mains cable 4
 - Maintenance
 - Daily maintenance 20
 - Maintenance 31
 - Messages, display 40
 - Milk foam 16
 - Milk, warm 16
- P**
 - Permanently setting the water for the cup size 17
 - Permanent settings in programming mode 22
 - Power switch 4
 - Preparation 14, 15
 - Cappuccino 15
 - Coffee 14
 - Espresso 14
 - Ground coffee 16
 - Latte macchiato 15
 - Milk 16
 - Ristretto 14
 - Problems
 - Troubleshooting 42
 - Programming mode 22
 - Automatic switch-off 26
 - Brightness of symbols 29
 - Energy-saving mode 25
 - Language 30
 - Products 23
 - Restore factory settings 27
 - Rinses 26
 - Unit for amount of water 29
 - Proper use 6
- R**
 - Rinses 26
 - Rinsing
 - Cappuccino frother 32
 - Machine 31
 - Ristretto 14
 - Rotary Switch 5
- S**
 - Safety 6
 - Safety information 6
 - Settings
 - Permanent settings in programming mode 22
 - Setting up
 - Setting up the machine 9
 - Short operating instructions 9
 - Switching off 21
 - Switching on 20
 - Switch-off
 - Automatic switch-off 26
 - Symbol description 3
- T**
 - Technical data 45
 - Telephone 48
 - Troubleshooting 42
- U**
 - Unit for amount of water 29
 - Use, First-time 10
- W**
 - Warm milk 16
 - Water tank 4
 - Descaling 39
 - Filling 9
 - Website 9

11 JURA contact details / Legal information

JURA Elektroapparate AG
Kaffeeweltstrasse 10
CH-4626 Niederbuchsiten
Tel. +41 (0)62 38 98 233

@ You will find additional contact details for your country at
www.jura.com.

- Directives** The machine complies with the following directives:
- 2006/95/EC – Low Voltage Directive
 - 2004/108/EC – Electromagnetic Compatibility
 - 2009/125/EC – Ecodesign

Technical changes We reserve the right to make technical changes. The diagrams used in these instructions for use are for illustration purposes only and do not represent the original colours of the machine. Some details of your IMPRESSA may vary.

Feedback Your opinion is important to us! Use the contact link at www.jura.com.

Copyright The instructions for use contain information which is protected by copyright. It is not permitted to photocopy these instructions for use or translate them into another language without the prior written consent of JURA Elektroapparate AG.